

Slider drive Linear Actuator Model No: KS_FY014

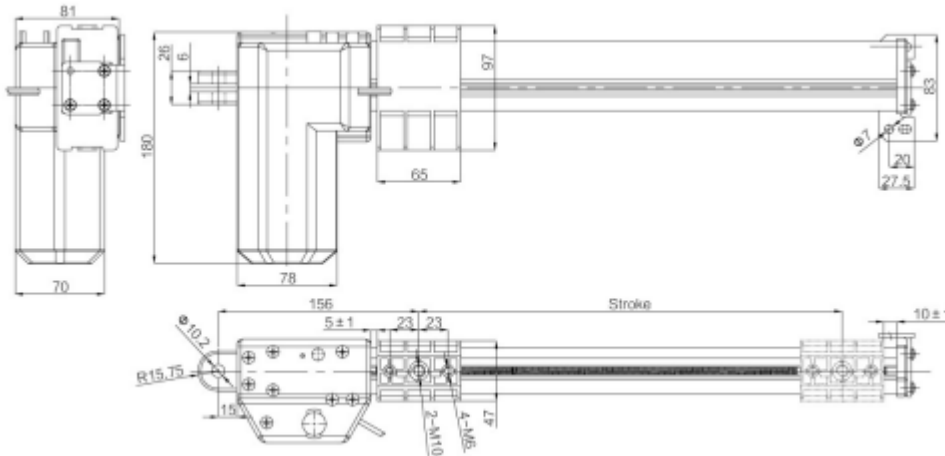

Application:

- Material Handling
- Factory Automation
- Packaging & converting

Other specifications:

Free load speed	18mm/s
Load capacity	1500N
Protection class	IP 20
Duty cycle	2 min on/18 min off
Stroke length	150 mm

Features:

- Compact design
- Aluminium frame & extension tube
- Built in limit switch
- Low noise
- Electrical operation only