

## Linear Actuator Model No: KS022

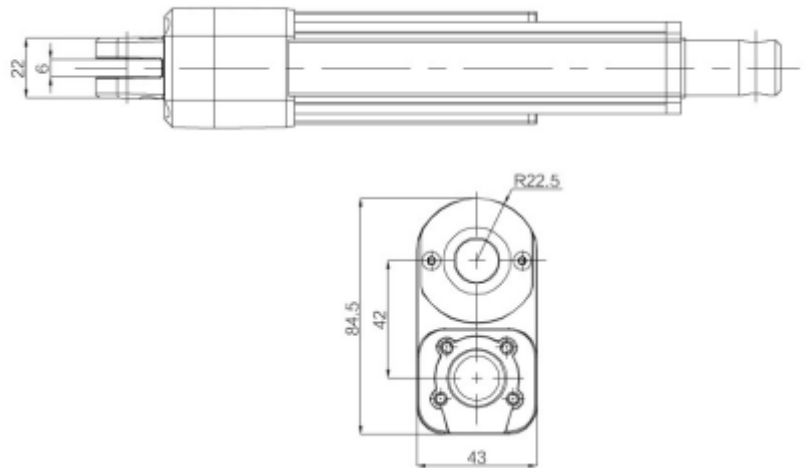

Other specifications :	
Free load speed	7mm/s
Load capacity	2500N
Protection class	IP65
Duty cycle	2 min on/18 min off
Stroke length	100mm

### Application:

- Material Handling
- Factory Automation
- Packaging & converting

### Features:

- Compact design
- Aluminium frame & extension tube
- Built in limit switch
- Low noise
- Electrical operation only