

Linear Actuator

Model No: KS_FY011C

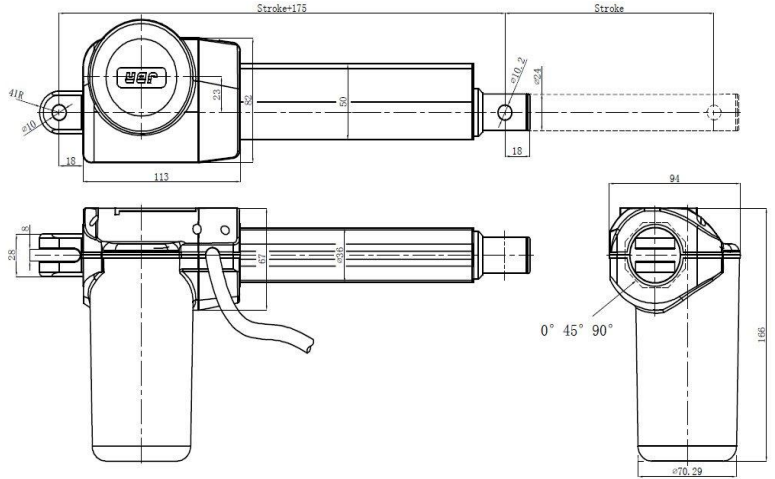

Other Specifications:

Free Load Speed	4mm/s
Load Capacity	6000N
Protection Class	IP65
Duty Cycle	2 min on/18 min off
Stroke Length	200mm

Features:

Application:

- Material Handling
- Factory Automation
- Packaging & converting

- Compact design
- Aluminium frame & extension tube
- Built in limit switch
- Low noise
- Electrical operation only