

Linear Actuator
Model No: KS_FY012

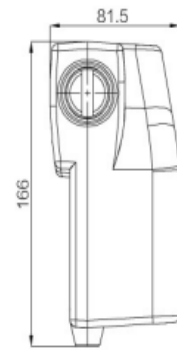
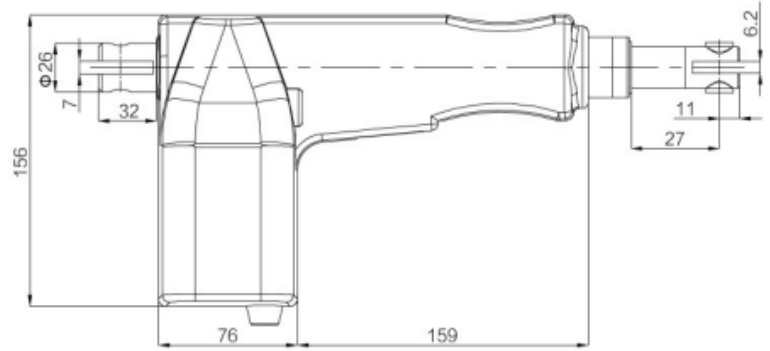

Other specifications :	
Free load speed	4mm/s
Load capacity	6000N
Protection class	IP54
Duty cycle	2 min on/18 min off
Stroke length	100mm

Application:

- Material Handling
- Factory Automation
- Packaging & converting

Features:

- Compact design
- Aluminium frame & extension tube
- Built in limit switch
- Low noise
- Electrical operation only